

**Rotary Switch Setting**

Position	MIN	50%	MAX
RV1 Operation Intervals (Minutes)	10	35	60
RV2 Operation time (Seconds)	3	6	10

**DIP Switch Settings**

SW1	1	2	3	4
ON	3-Wire Float	Not In Use	Not In Use	DEMO MODE
OFF	2-Wire Float	Not In Use	Not In Use	Standard Mode

<p>Shabbat Smart Ltd. 85 Kenilworth Road London HA8 8XA United Kingdom Tel: +44 20 8004 9558 email: info@ShabbatSmart.com www.ShabbatSmart.com</p>	<p><b>Name:</b> ShabbatSmart Waste Water Pump Controller</p> <p><b>Scale:</b> NTS</p>
	<p><b>Description:</b> Wiring Diagram</p> <p><b>Page:</b> A4</p>
	<p><b>Version:</b> 1.2</p> <p><b>Date:</b> 23/09/2021</p>

# FW: BMS Manual pump station B

**From:** Pumps @ Delta Membrane Systems Ltd <[pumps@deltamembranes.com](mailto:pumps@deltamembranes.com)>

**Sent:** 21 February 2023 10:00

**To:** Daniel Le'Andre <[daniel@tenways.co.uk](mailto:daniel@tenways.co.uk)>

**Subject:** BMS Manual pump station B

Hi Daniel

We thank you for the opportunity to create a specification for your mechanical drainage pump system.

Following your recent enquiry, please find our specification for the pump stations required for the above project.

The pump specification is based on the requirements from the information provided to us for the mechanical discharge of water from a Foul water system.

## Foul Water Pump Station

Pump Station B

1no DMS1654-2 Delta Single Foul 895x750 with Manual Ama-porter 501m pump @ £762.39 + vat

2no DMS-E158 Pendent Float for Foul water pump station @ £49.95 each + vat

The calculations provided have been based on the chamber being level with the structural slab or at the recommended maximum depth of 500mm from the top of the finished floor level.

If the dimensions do not fall within these parameters, please contact us to review the specification and invert levels.

Regards



**Jason Derry CSSW**  
**General Manager**  
**Mobile: 07799 910 810**  
**Office: 01992 523 523**  
**[www.deltamembranes.com](http://www.deltamembranes.com)**



to allow Shabbat Smart control use a Manual Pump (no float switch attached directly to the pump)

**Description**

The Delta Foul V3 Submersible Pump is designed as a compact and cost-effective solution for collection of foul and/or grey water from basements, below ground structures and ground floor extensions.

The robust and reliable Delta Foul V3 is an exceptionally popular choice with waterproofing professionals due to its generous sized motor, thermal overload protection and ease of installation.

The powerful Vortex pump offers innovative design and advanced technology making it extremely reliable even when subjected to continuous use (subject to correct installation). With a 45mm solids clearance the Delta Foul V3 offers reliable and effective dewatering.

The Delta Foul V3 can be supplied free standing or on pedestal mounting for permanent installation.

The Delta Foul V3 Submersible pump is not suitable for collecting ground water from a Cavity Drained System.

**Features**

- Maximum flow rate up to 6.3 l/s
- Maximum head (lift height) 12m
- 2" BSP threaded pump outlet
- Trouble free operation
- Free flowing impeller (preventing clogging)
- Corrosion resistant stainless-steel shaft and bi-rotational mechanical seal
- Designed for easy installation
- Operates via a control panel
- Available with pedestal mounting

**Specification**

- Pumps set: 2006/42/EC EC Machinery Directive
- Electrical components: 2011/65/EU Restriction of the use of certain hazardous substances in electrical and electronic equipment (RoHS)
- Electromagnetic Compatibility: 2014/30/EU
- ISO 12100
- EN 809
- EN 60034-1, EN 60034-5/A1
- EN 60335-1/A1, EN 60335-2-41

**Product details**

DMS E029



**Associated products**

- Delta Bespoke 800 Series – Dual V3 Foul



# PRODUCT DATA SHEET

## Delta Foul V3 Submersible Pump (Manual)

### Technical data

Pump type	Foul V3
Pump type	Vortex
Control	Manual
Power supply	230 VAC
Rated current	6.0 A
Motor rating (P2)	750 W
Revs per min.	2900 rpm
Discharge size	DN50
Free passage	45 mm
Max. vertical	12 m
Max. flow rate	6.3 l/s
Max liquid temp.	<40 °C
Cable length	10 m
Weight	23.0 kg

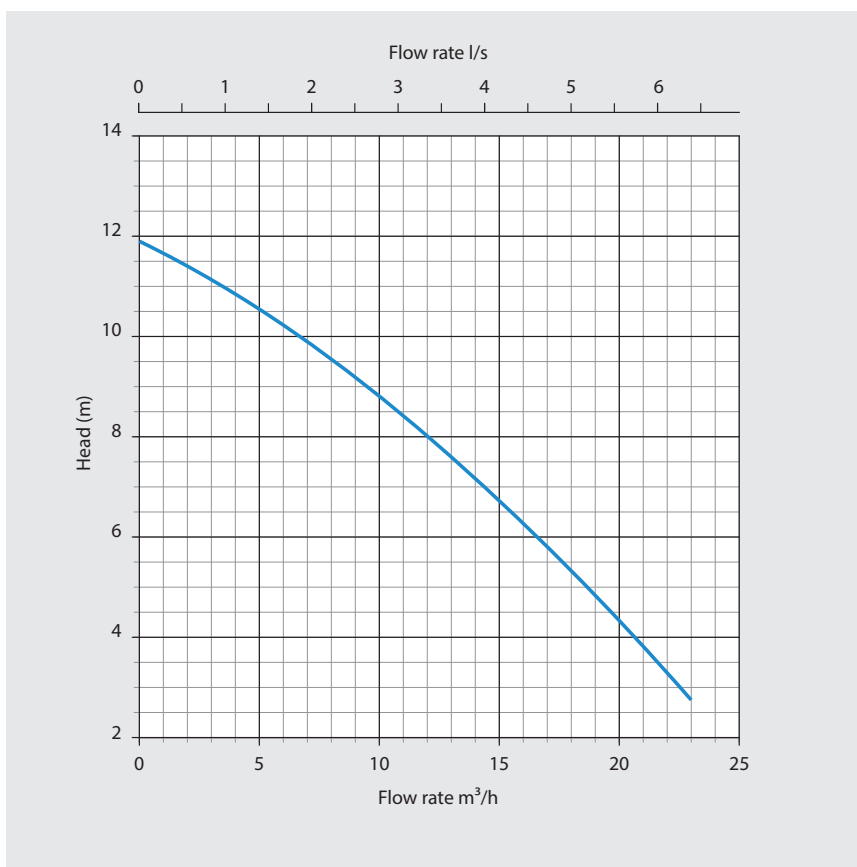

### Other information

All data and information contained in these Product/Technical Data Sheets is up-to-date and correct as at the date of issue. The information given is suggested as guidance and should only be used for evaluating your specific application. Delta Membrane Systems Limited cannot control or anticipate the conditions under which this product may be used, each user should review the information in specific context of the planned use. The information contained in these Product/Technical Data Sheets should not be considered a warranty, expressed, or implied, including but not limited to a warranty of merchantability or fitness for a particular purpose. In no event shall Delta Membrane Systems Limited be liable for any incidental or consequential damages resulting from the use, misuse, or inability to use the product. This exclusion applies regardless of whether such damages are sought based on breach of warranty, breach of contract, negligence, strict liability in tort, or any other legal theory. When in doubt, contact Delta's Technical Team on 01992 523 523.

**DELTA MEMBRANE SYSTEMS LTD**

# 895 CHAMBER - FOUL AND GREY WATER

The Delta 895 chambers are designed for foul and grey water collection.

The Delta V3 Foul Packaged Pump Stations are suitable for collecting wastewater from the kitchens, bathrooms and/or utility rooms and discharging this into the mains drainage system.

The Delta Foul V3 is an effective way of moving foul/grey water to where it needs to be.

This specially designed chamber offers a large storage dimension, not forgetting the all-important cost savings – less excavation costs, less labour costs, less requirement for concrete/steel (when housed).

Recommended RC Sump Dimension - 1000mm x 1000mm x 1000mm

Delta 895 Chamber size - 895mm x 660mm (750mm spigot to spigot)

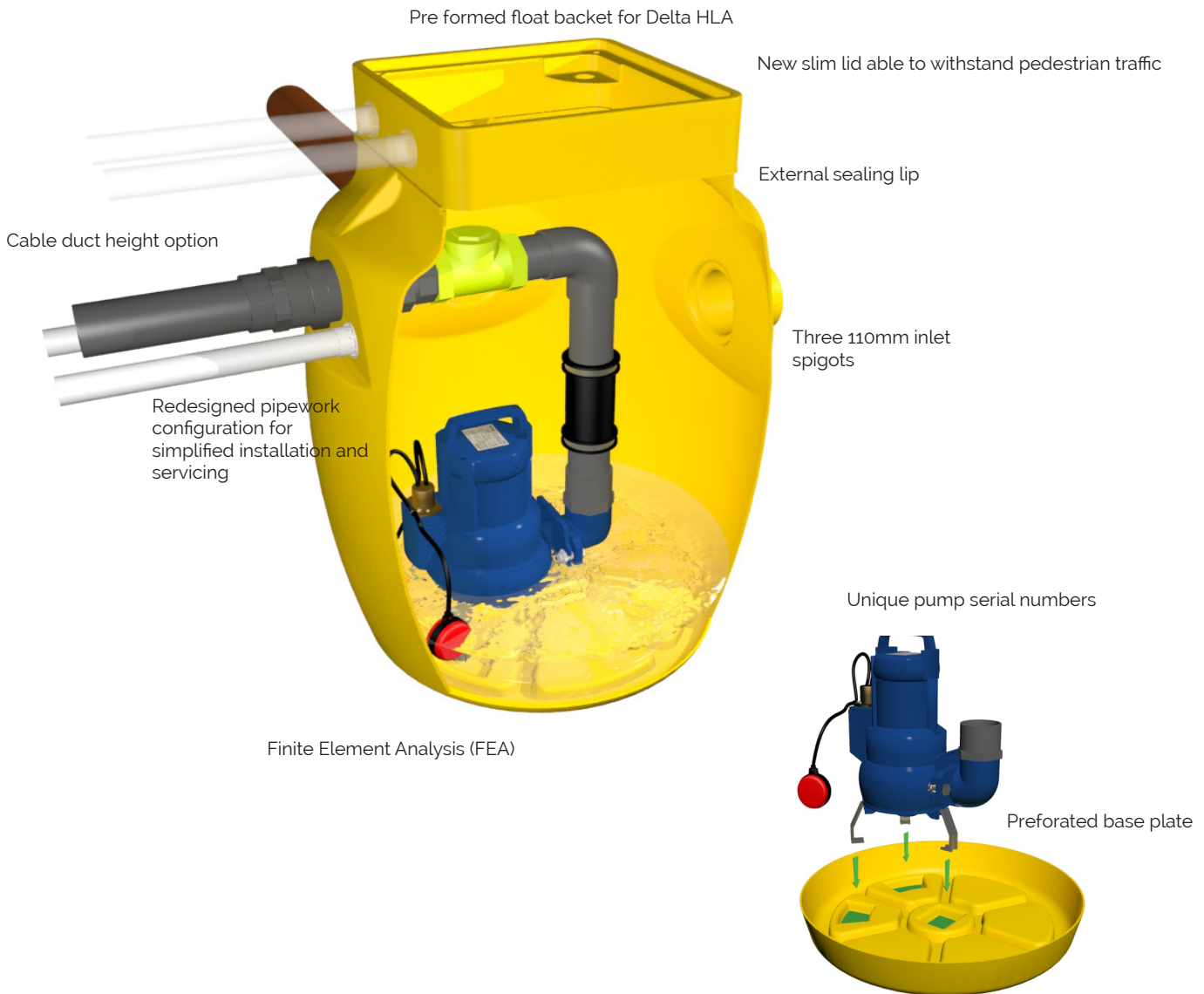



# INSTALLATION GUIDE

## Delta Foul V3 Packaged Pumping Station



[www.deltamembranes.com](http://www.deltamembranes.com)

**THIS MANUAL SHOULD BE KEPT WITH  
THE PUMP STATION OR THE HOMEOWNER**

# Contents

1.	Delta Foul V3 overview .....	1
1.1	Delta Foul V3 overview.....	1
1.2	Example installation .....	1
1.3	Parts included .....	1
1.4	Optional extras.....	1
1.5	Technical information .....	2
2.	Discharge pipework and fittings .....	3
2.1	Discharge pipework and fittings.....	3
2.2	Spare parts.....	4
3.	Pump chamber depth limits.....	5
4.	Installation guidelines.....	6
4.1	Installation guidelines .....	6
4.2	Pump station location .....	6
4.3	Installation within a reinforced concrete sump.....	6
4.4	Cable duct guidance.....	7
4.5	Vent duct guidance.....	7
5.	Installation of the chamber.....	8
5.1	Construction of a reinforced concrete box (recommended).....	8
5.2	Construction of a reinforced cage .....	10
5.3	Connection of 110 mm inlet pipework.....	11
5.4	Connection of discharge/cable duct and vent .....	12
5.5	Backfill around chamber with concrete (RC box) .....	14
5.6	Concrete backfill around chamber (with reinforced cage).....	15
5.7	Preparing chamber for submersible pump installation.....	16
5.8	Installing pump in chamber with high-water level alarm (Delta HLA) .....	17
6.	Wiring diagrams.....	20
6.1	Wiring diagram with Delta HLA.....	20
6.2	Wiring diagram with Delta Battery Backup .....	21
7.	Maintenance .....	22
8.	Health and safety .....	22
9.	Warranty .....	23
10.	Troubleshooting .....	24
11.	Ancillaries.....	25
12.	Commissioning details.....	27



# 1. Delta Foul V3 overview

## 1.1 Delta Foul V3 overview

The Delta Foul V3 packaged pumping station has been specifically designed to collect foul and/or grey water from basements, below ground structures and ground floor extensions.

It is not suitable for collecting ground water from a cavity drained system.

The pump station has been specifically designed for below ground applications. The chamber is manufactured from HDPE and when installed correctly, it is able to withstand hydrostatic forces encountered in high water tables.

The pump station is delivered as a complete package including, the chamber, internal pipework and a powerful automatic Delta Foul V3 submersible pump.

It is designed to be installed by contractors with competent building, plumbing and electrical skills.

A Delta HLA high level alarm (DMS 191) is a recommended extra to alert the property occupant when the water level in the chamber becomes too high.

A Delta Battery Backup Foul V3 (DMS E030) is recommended to power the pumps during power outage. Please see Section 1.4 for more details about optional extras designed for the Foul V3 pump station.

## 1.2 Example installation

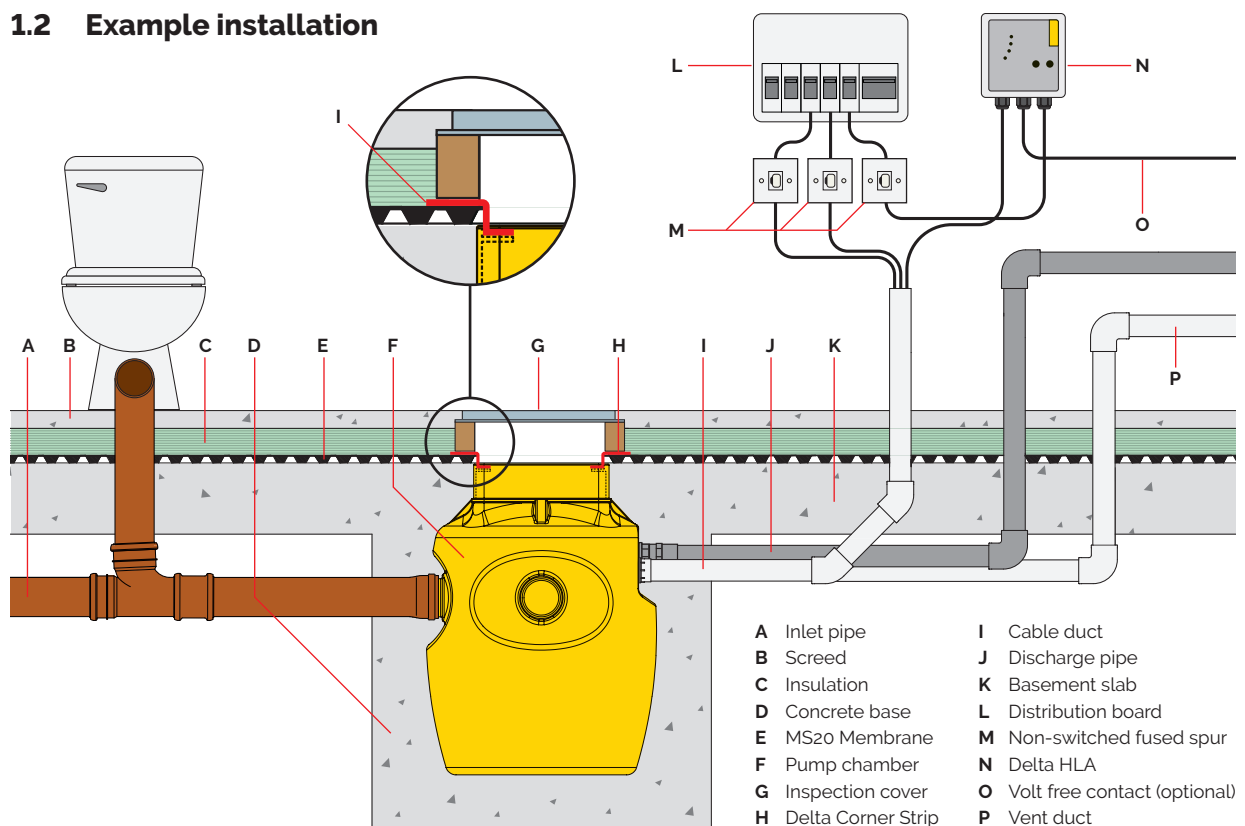

## 1.3 Parts included

- Chamber – 750 x 895mm deep
- 2" internal pipework
- 1 x Delta Foul V3 submersible pump
- 2" discharge socket (plain/threaded)
- 2" cable duct male iron
- 2" vent duct male iron.

## 1.4 Optional extras

- Delta HLA – high level alarm (DMS 191)
- Delta Battery Backup Foul V3 (DMS E030)
- 2" discharge pipework and various fittings

## 1.5 Technical information

### Pump specification

Pump type	Foul V3	
Power	$P_1$ (kW)	1.25
	$P_2$ (kW)	0.75
Rated current (A)	6.0	
Power phase	Single	
Non-switched fused spur rating (A)	13	
RCBO rating (A)	10	
Cable length (m)	10	
Max. temperature (°C)	40	
Weight (kg)	22.0	

### Chamber specification

Chamber material	HDPE (ICO1314 grade)	
Size (mm)	Chamber diameter	660
	Overall diameter	750 (across spigots)
	Depth	895
Volume (l)	Below inlet	155
	Total	273
Inspection cover	Not supplied	
Clear opening to chamber (mm)	310 x 310	
Fixed inlets (mm)	3 x 110	
Cable duct (mm)	50	
Vent (mm)	50	
External discharge connection	2" PVC Class E	
Internal pipework manifold	2" PVC Class E	

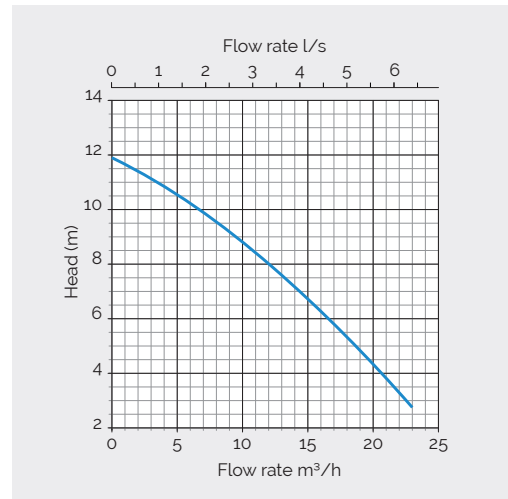

All dimensions are in millimetres (mm) and are to the invert level (bottom of pipe). All capacities are in litres (l).



### Positioning connections

Discharge only
Inlet location allowed
Inlet, cable ducts or vent allowed
Cable ducts and vents only
No drilling allowed

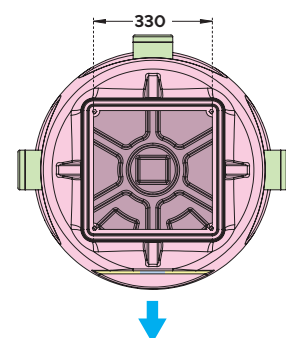
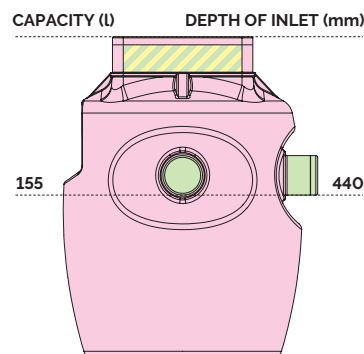
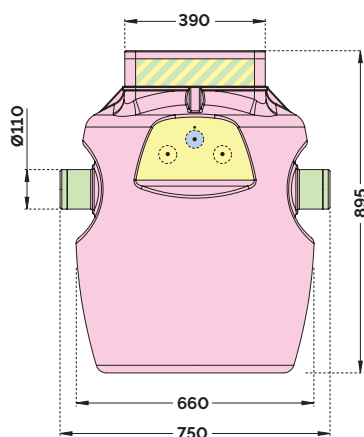

# 2. Discharge pipework and fittings

## 2.1 Discharge pipework and fittings

A selection of discharge pipework and fittings are available for the Delta Foul V3 pump station.

Should you require to place an order for any of these items, please complete the form below, scan and email to pumps@deltamembranes.com to allow us to process your order.

Part description	Part no.	Qty req.
2" pipe – 2 m length (PVC Class E)	DMS-E120	<input type="text"/>
2" 90° elbow – plain/plain	DMS-E121	<input type="text"/>
2" 45° elbow – plain/plain	DMS-E122	<input type="text"/>
2" socket – plain/plain	DMS-E123	<input type="text"/>
2" socket – BSP female thread/BSP female thread	DMS-E131	<input type="text"/>
2" male iron – plain/BSP male thread	DMS-E124	<input type="text"/>
50 mm male iron – plain/BSP male thread (non-pressure)	DMS-E132	<input type="text"/>
Saddle clamp – 110 mm to 2" (BSP female thread)	DMS-E133	<input type="text"/>
2" pipe clip	DMS-E202	<input type="text"/>
250 ml PVC solvent cement c/w brush	DMS-E175	<input type="text"/>

Name:	
Company name:	
Delivery/site address:	
Email:	
Telephone number:	Mobile Number:
Signature:	Date:

**Please scan this order form and email to pumps@deltamembranes.com**

## 2.2 Spare parts

Part	Description	Part No.
A	Delta Foul V3 Pump (Automatic)	DMS-120
B	2" male threaded adaptor	DMS-E124
C	2" pipe (PVC Class E)	DMS-E120
D	Rubber drain coupling c/w jubilee clips	DMS-E174
E	2" 90° elbow – plain/plain	DMS-E121
F	2" barrel nipple – plain/threaded	DMS-E128
G	2" brass swing check valve	DMS-E193
H	2" tank connector	DMS-E130
I	2" non-pressure male iron	DMS-E132
J	2" socket plain/threaded	DMS-E127

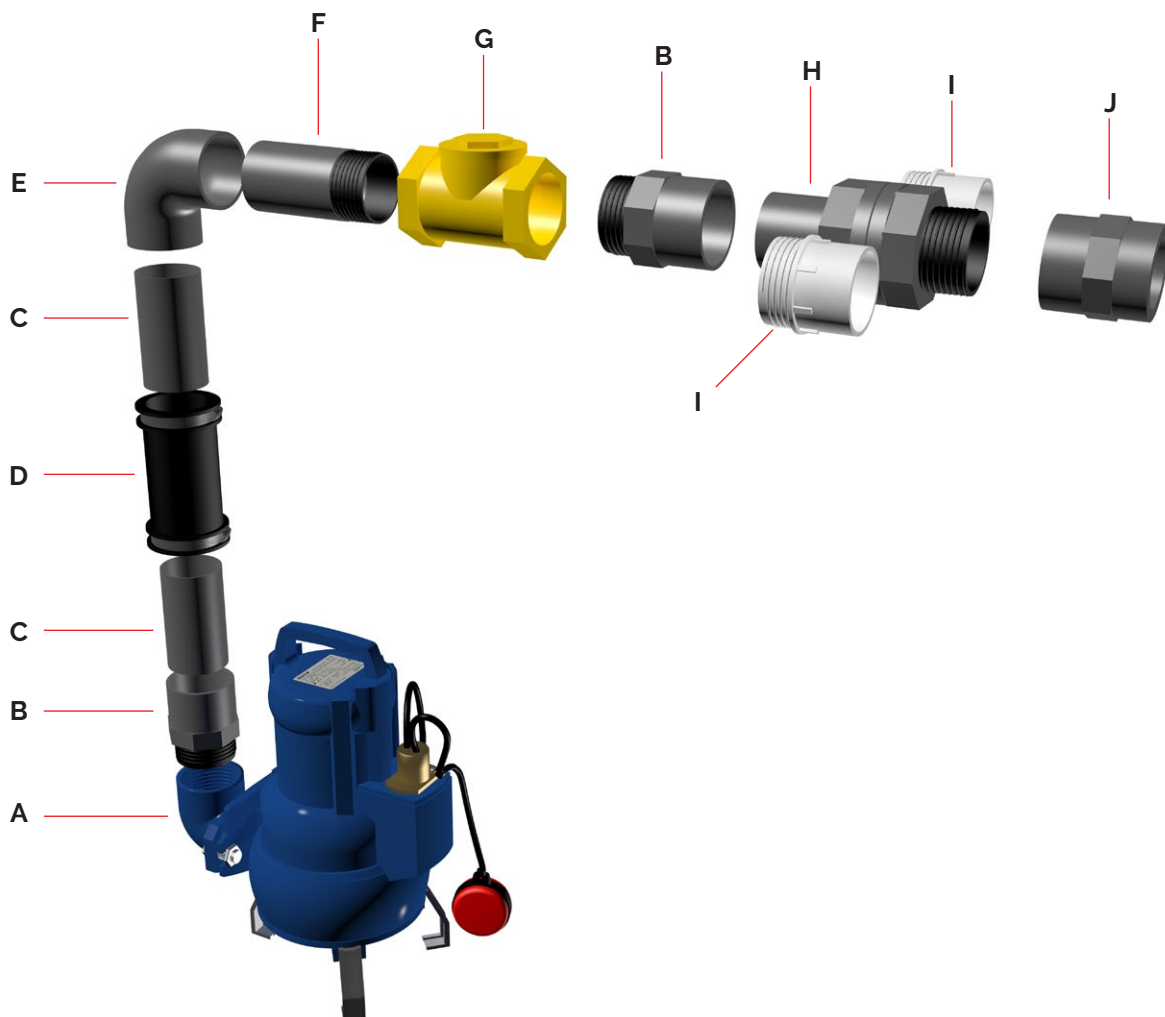

# 3. Pump chamber depth limits

The chamber must be installed less than 500 mm below the finished floor level (FFL) so that it can be serviced safely in accordance with the Construction (Design and Management) Regulations 2015 (CDM).

If the inlet inverts to not allow installation within this depth limit, please discuss chamber options with Delta Membranes on 01992 523 523 between 8am and 5pm, Monday to Friday or by email at [info@deltamembranes.com](mailto:info@deltamembranes.com).

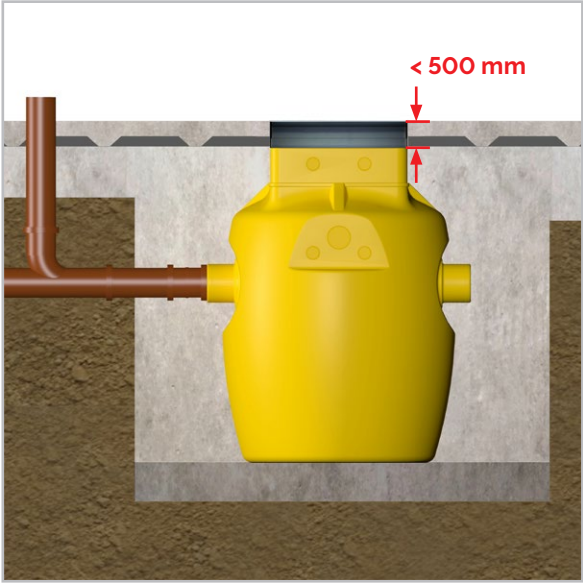

**Less than 500 mm below FFL**

The pump chamber must be installed no greater than 500 mm below FFL.

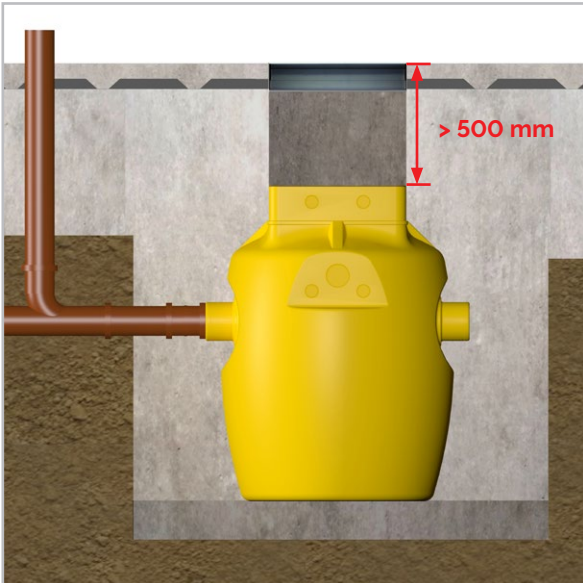

**More than 500 mm below FFL**

The chamber must not be installed at a depth below FFL greater than 500 mm.

It cannot be serviced safely in accordance with The Construction (Design and Management) Regulations 2015.



# 4. Installation guidelines

## 4.1 Installation guidelines

This guide is an illustration of installation guidelines which should be followed for proper installation of the Delta Foul V3 submersible packaged pump station, including housing. It is important to note these instructions are for guidance only and it is the installer's responsibility to satisfy themselves that the installation procedure is in accordance with the prevailing ground conditions and good build practice, to eliminate any potential damage to the pump station chamber either during or after installation. The installer should also satisfy themselves that the system can be installed in conjunction with these guidelines, prior to work commencing.

Please read these instructions in full, prior to the commencement of installation. If you are unsure on any aspect, the ask for advice before proceeding by contacting Delta Membranes on 01992 523 523 between 8am and 5pm, Monday to Friday or by email at [info@deltamembranes.com](mailto:info@deltamembranes.com).

## 4.2 Pump station location

The Delta Foul V3 Packaged Pump Station requires routine maintenance, it is important that careful consideration is taken to position the chamber in a location which will allow for permanent access.

## 4.3 Installation within a reinforced concrete sump



**A structural and waterproofing engineer must be consulted when designing the waterproof reinforced concrete sump and backfill to ensure that it can withstand the anticipated pressures, and that they are not transferred onto the chamber.**

The chamber is manufactured from tank-grade polyethylene and is extremely robust. However, as with all pre-formed chamber they are susceptible to floatation and hydrostatic pressures exerted in high water table conditions.

To ensure these forces are not transferred onto the chamber, we strongly recommend the chamber is installed within a waterproof reinforced concrete (RC) sump.

Furthermore, when constructing the waterproof reinforced concrete sump, adequate space must be made for connections to the chamber e.g. inlets, discharge, cable and vent ducts. Consideration must also be made to the depth and orientation of all connections to ensure that they line up with the chamber.

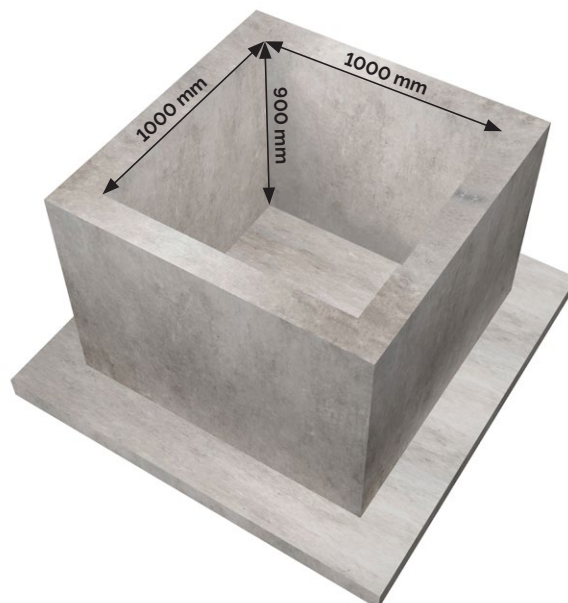

## 4.4 Cable duct guidance



It is vital to pull a draw cord through the cable duct as it is being constructed so that pump and float cables can be pulled through during installation. Ensure the cord's loose end cannot slip back into the duct.

The cable duct for the Delta Foul V3 packaged pumping station should be 50 mm diameter. This can be low pressure ABS waste pipe or high pressure PVC. The cable duct can be positioned on any flat face of the chamber neck below the scribe line, or on the discharge face (please refer to Sections 1.5 & 5.4).

### 4.4.1 CONSTRUCTING THE CABLE DUCT

To allow cables to be easily pulled through the cable duct use sweeping corners instead of tight 90 degree elbows. These can be created by using two 45 degree elbows.

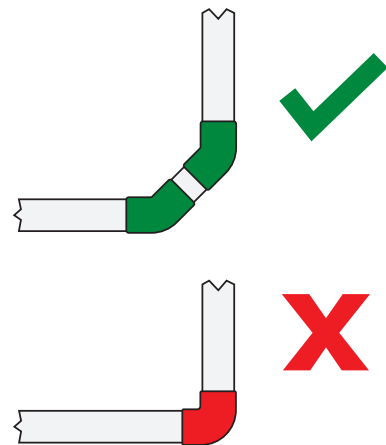
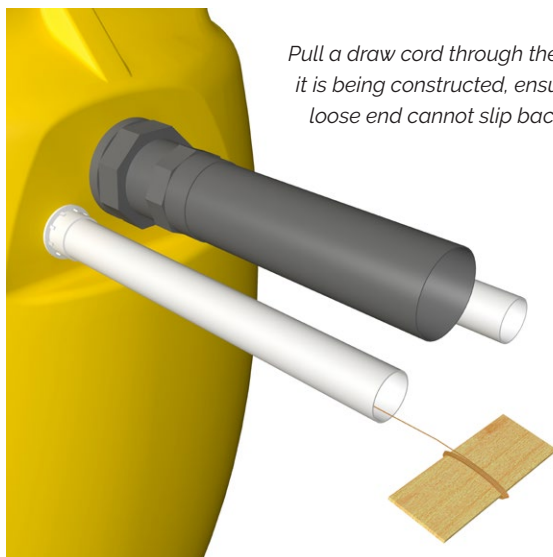

Swept bends allow the cables to be pulled through the cable duct.

### 4.4.2 CABLE EXTENSIONS

If cable extensions are required for the pump power cable or the float cable, a qualified electrical contractor must make all electrical connections. Suitable cable extension kits are available to order. Please contact Delta Membranes on 01992 523 523 between 8am and 5pm, Monday to Friday or by email at [info@deltamembranes.com](mailto:info@deltamembranes.com) for more information.

## 4.5 Vent duct guidance

If the pumping station receives foul and/or grey water then a vent duct must be installed. This duct must be vented to atmosphere. An air-admittance (Durgo) valve must not be installed.

The vent duct's primary purpose is to equalise pressure within the chamber. It will also mitigate any odours from foul waste in base of the chamber.

The vent duct should be 50 mm waste pipe. The vent duct can be positioned on any suitable flat face of the chamber neck below the scribe line, or on the discharge face (please refer to Sections 1.5 & 5.4).

When installing in conjunction with a cavity membrane system, care must be taken to prevent foul odours from being transmitted to the cavity. Seal the interface with Delta Corner Strip (DMS 020).

# 5. Installation of the chamber

## 5.1 Construction of a reinforced concrete box (recommended)

We strongly recommend the chamber is installed within a reinforced concrete box.



Excavate hole for chamber. Refer to section 4.3 for RC box internal dimensions.

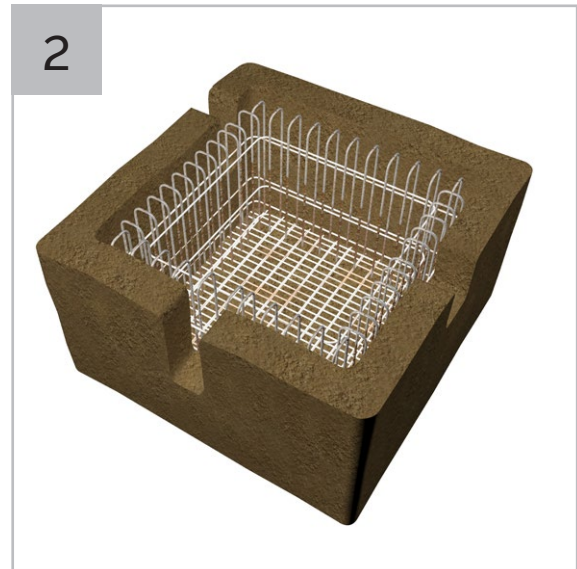

Install re-bar as per structural engineer's details.

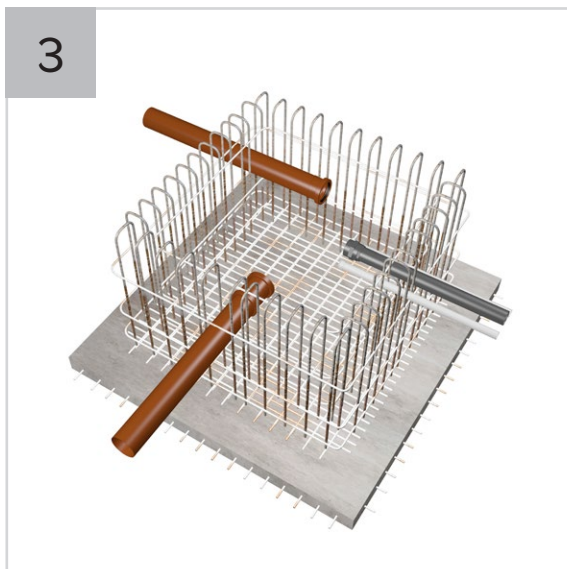

Lay inlet and discharge pipework. Allow pipework to protrude into RC box by a minimum of 100 mm.

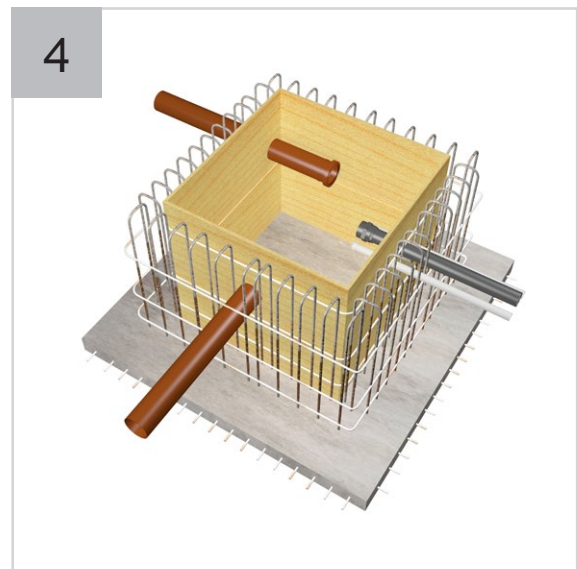

Create shuttering.



## 5. Installation of chamber

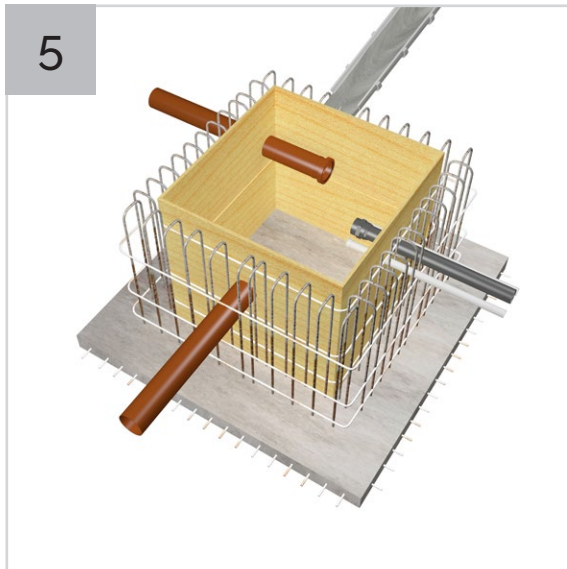

Pour concrete to form the reinforced concrete box as per structural engineer's details.

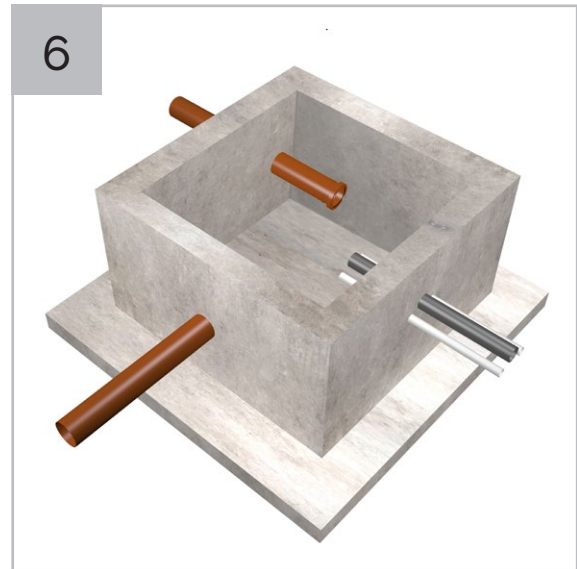

Allow the concrete to cure and then remove the shuttering.

**Go to Section 5.3 »**

## 5.2 Construction of a reinforced cage

We strongly recommend the chamber is installed within a reinforced concrete box (Section 5.1). For installation in a reinforced cage only, follow steps below instead.



Excavate hole for chamber. Refer to section 4.3 for RC box internal dimensions.



Install re-bar as per structural engineer's details.

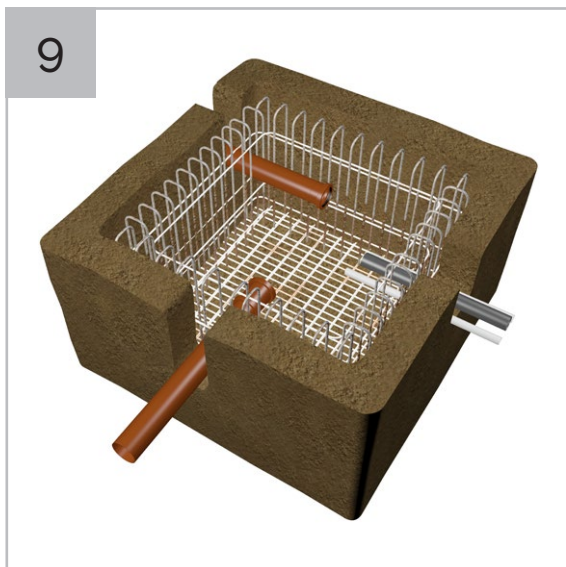

Lay inlet and discharge pipework. Allow pipework to protrude into cage by a minimum of 100 mm.

**Go to Section 5.3 >>**

## 5. Installation of chamber

### 5.3 Connection of 110 mm inlet pipework

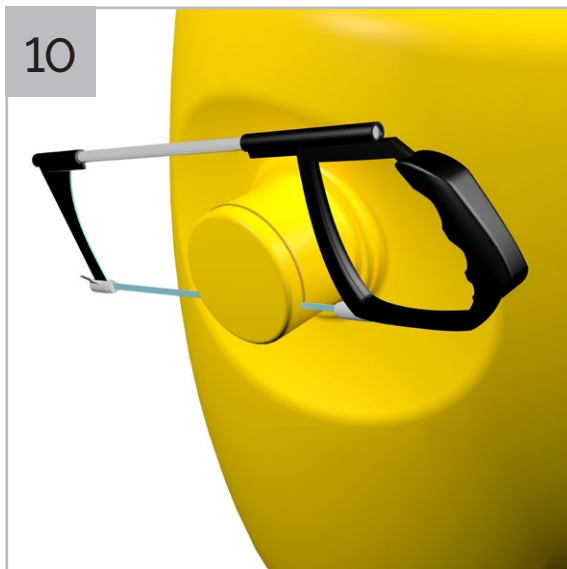

Saw off socket ends, where inlet pipes are to be connected.

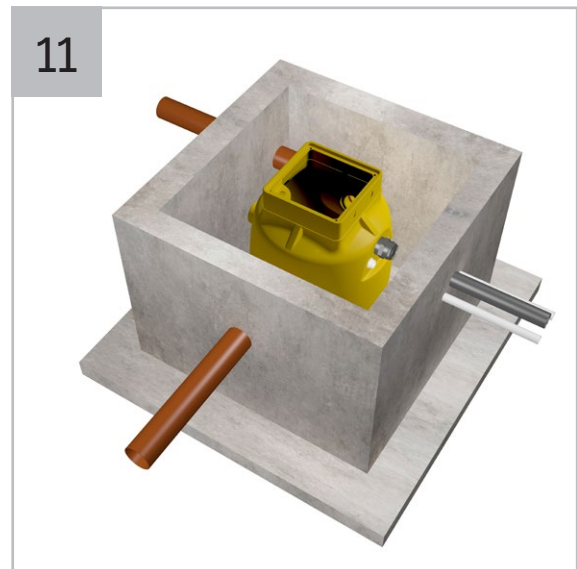

Position chamber in RC box.

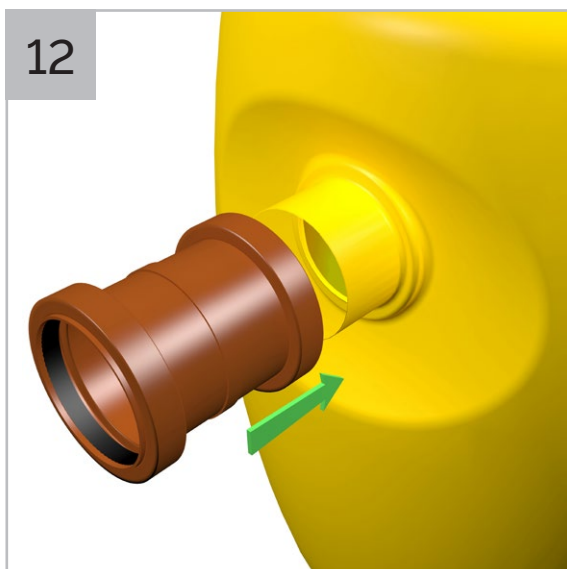

Fit push fit coupler.

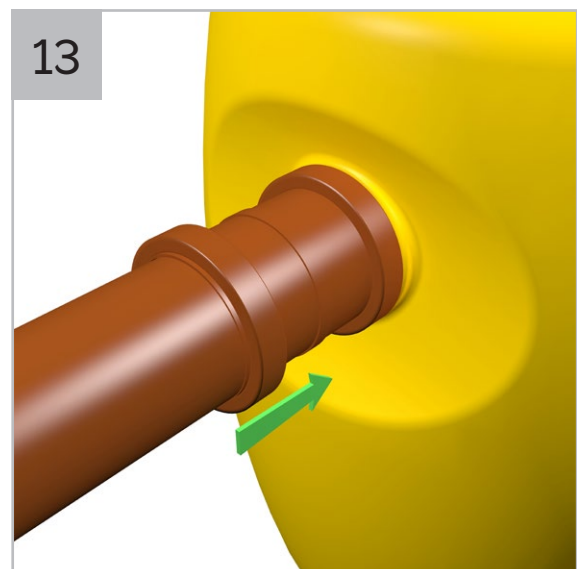

Connect inlet pipework to the chamber spigot.

**Go to Section 5.4 »**

### 5.4 Connection of discharge/cable duct and vent

Cable ducts and vents can be positioned to suit site requirements, either on the chamber neck or on the discharge face. Please refer to the diagram in Section 1.5 for more details. If drilling into the neck, do not cut the chamber above the scribe line. Guide holes are provided on the discharge face for easy positioning.

Use a 60 mm hole saw and arbor (DMS E218). For illustration we are using the lower cable duct/vent pipe position on the discharge face.



Wrap the thread on the tank connector's male thread with PTFE tape.



Securely fasten the plain/threaded socket onto the thread of the tank connector.



Apply Delta Solvent Cement around the first 20 mm of the external face of the discharge and cable duct pipe and internal side of their respective fittings.

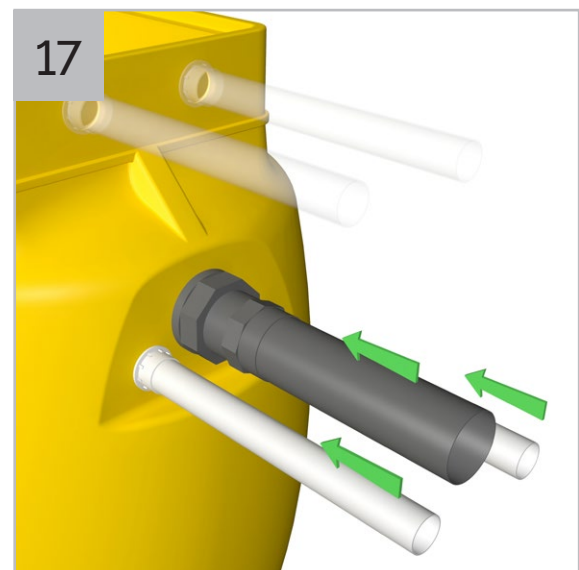

Push discharge and cable duct pipe into their respective fittings, twisting the pipe as it is pushed in to remove any trapped air.

## 5. Installation of chamber

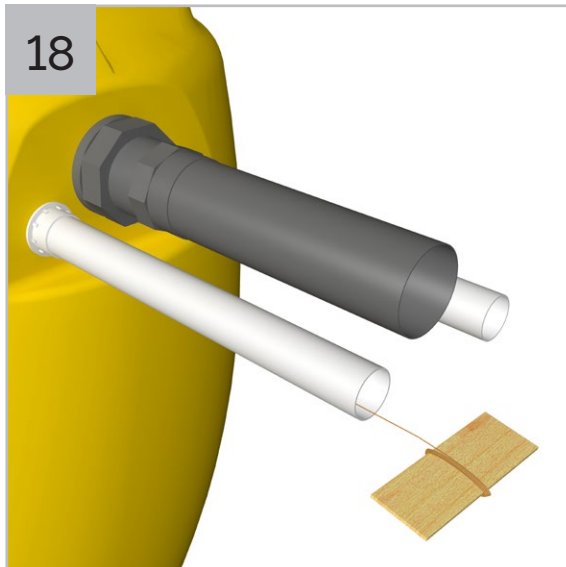

Ensure a draw cord is pulled through the cable duct as the cable duct is built.

**If you are installing the chamber in a reinforced concrete box, go to Section 5.5 »**

**If you are installing the chamber in a reinforced cage, go to Section 5.6 »**

### 5.5 Backfill around chamber with concrete (RC box)

To be followed when installing chamber in a reinforced concrete (RC) box.

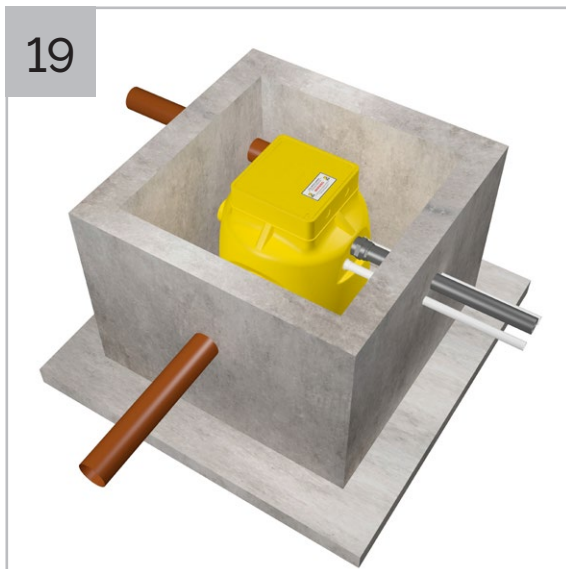

19 Check all pipes are connected to the chamber correctly.

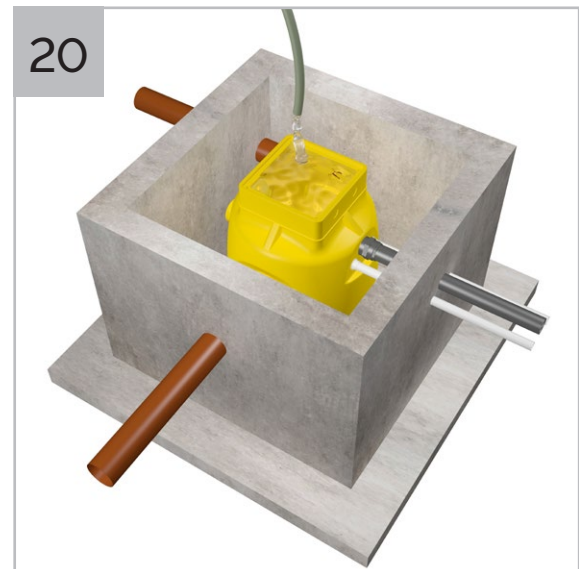

20 Completely fill chamber with water.



21 Once chamber has been filled with water, apply Delta AKTI-VO 201 (swellable mastic) to the entire external lip locator of chamber.



22 Fill void between RC box and chamber with concrete (we recommend use of C35 grade/PAV2 as a minimum) or as per the structural engineer's details.

**Go to Section 5.7 »**

5. Installation of chamber

**5.6 Concrete backfill around Chamber (with reinforced cage)**

To be followed when installing chamber directly in the ground.

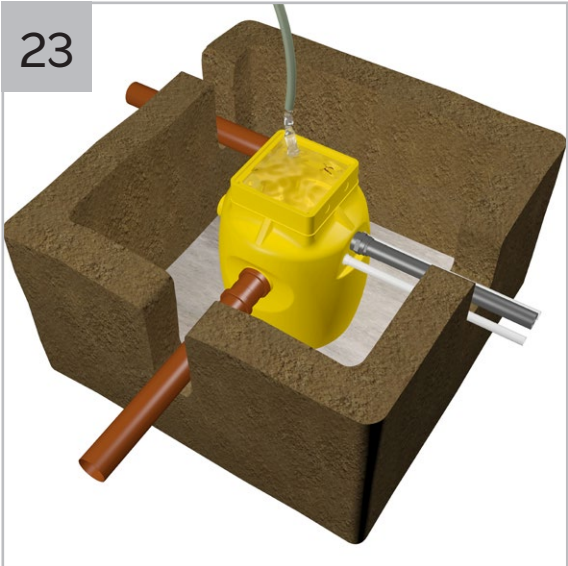

Completely fill chamber with water.



Once chamber has been filled with water, apply Delta AKTI-VO 201 (swellable mastic) to the entire external lip locator of chamber.

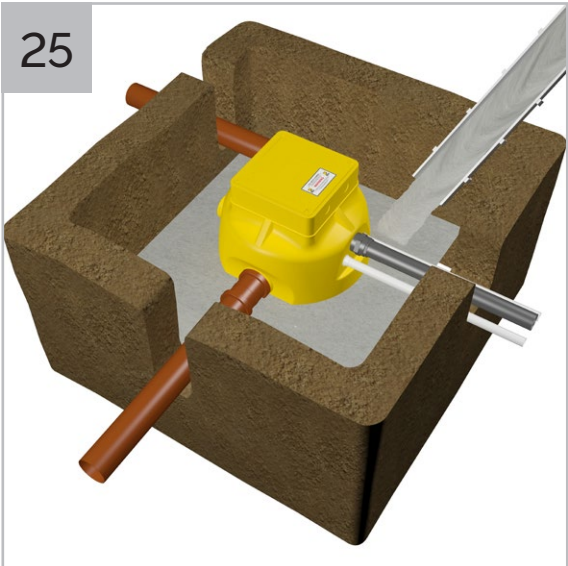

Fill void between soil and chamber with concrete (we recommend use of C35 grade/PAV2 as a minimum) or as per the structural engineer's details.



Allow concrete to cure.

**Go to Section 5.7 »**

### 5.7 Preparing chamber for submersible pump installation



Once successfully installed all chambers should be emptied. Use of temporary site pump(s) are suitable for this exercise. Care should be taken in ensuring water is being discharged somewhere suitable.



Manually remove any debris from chamber and residual water using a wet vacuum.

**Go to Section 5.8 >>**



## 5. Installation of chamber

### 5.8 Installing pump in chamber with high-water level alarm (Delta HLA)

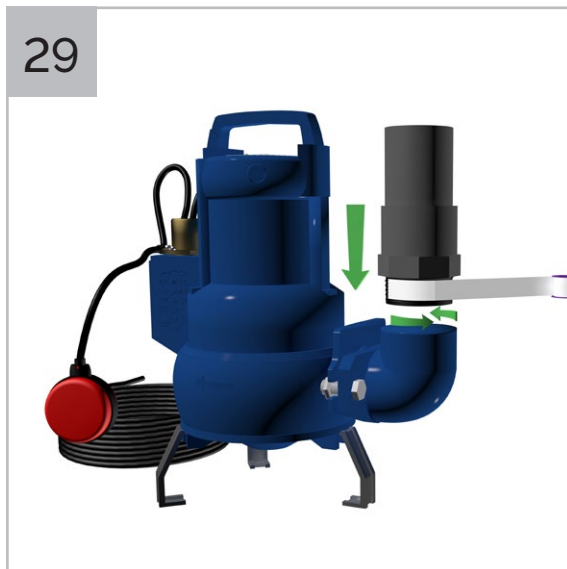

Wrap PTFE tape around thread located on male iron at the bottom of the discharge arm and screw discharge arms on to pump.



Fill chamber half full with water.

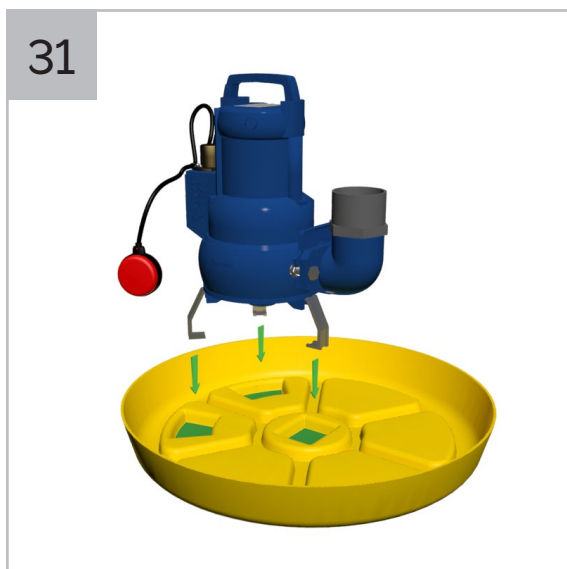

Position the pump in the chamber base ensuring the legs are sited in the moulded depressions.



Push pipe into the rubber drain coupling.

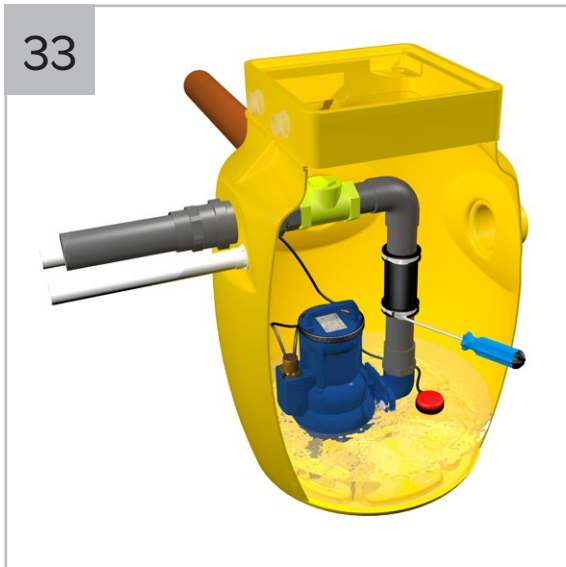

Tighten the jubilee clips to seal the rubber drain coupling to the pipe.



When installing a Delta HLA high level alarm, please refer to the Delta HLA installation instructions.

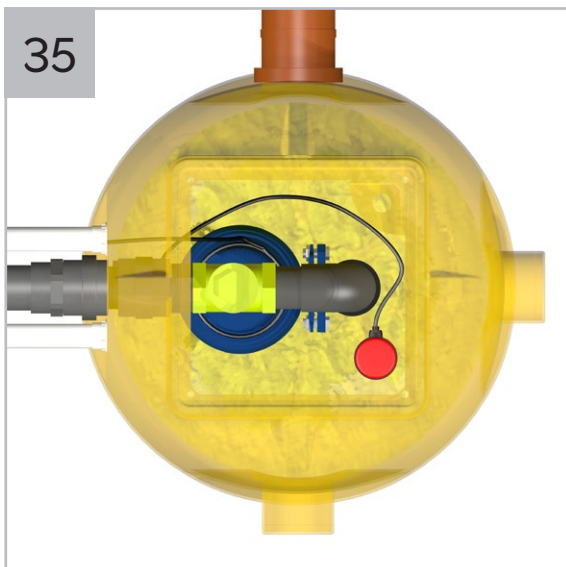

Pull pump and high level alarm cables through cable duct.



Isolate main supply and connect the pump to a separate non-switched fused spur. When installing a Delta HLA, follow the wiring diagram on page 18.

5. Installation of chamber



Turn mains supply on and lift the pump float to test the water is discharging correctly.



To test float switch, refer to the Delta HLA installation instructions.



Re-fit temporary site cover to protect the pump station.

# 6. Wiring diagrams

## 6.1 Wiring diagram with Delta HLA

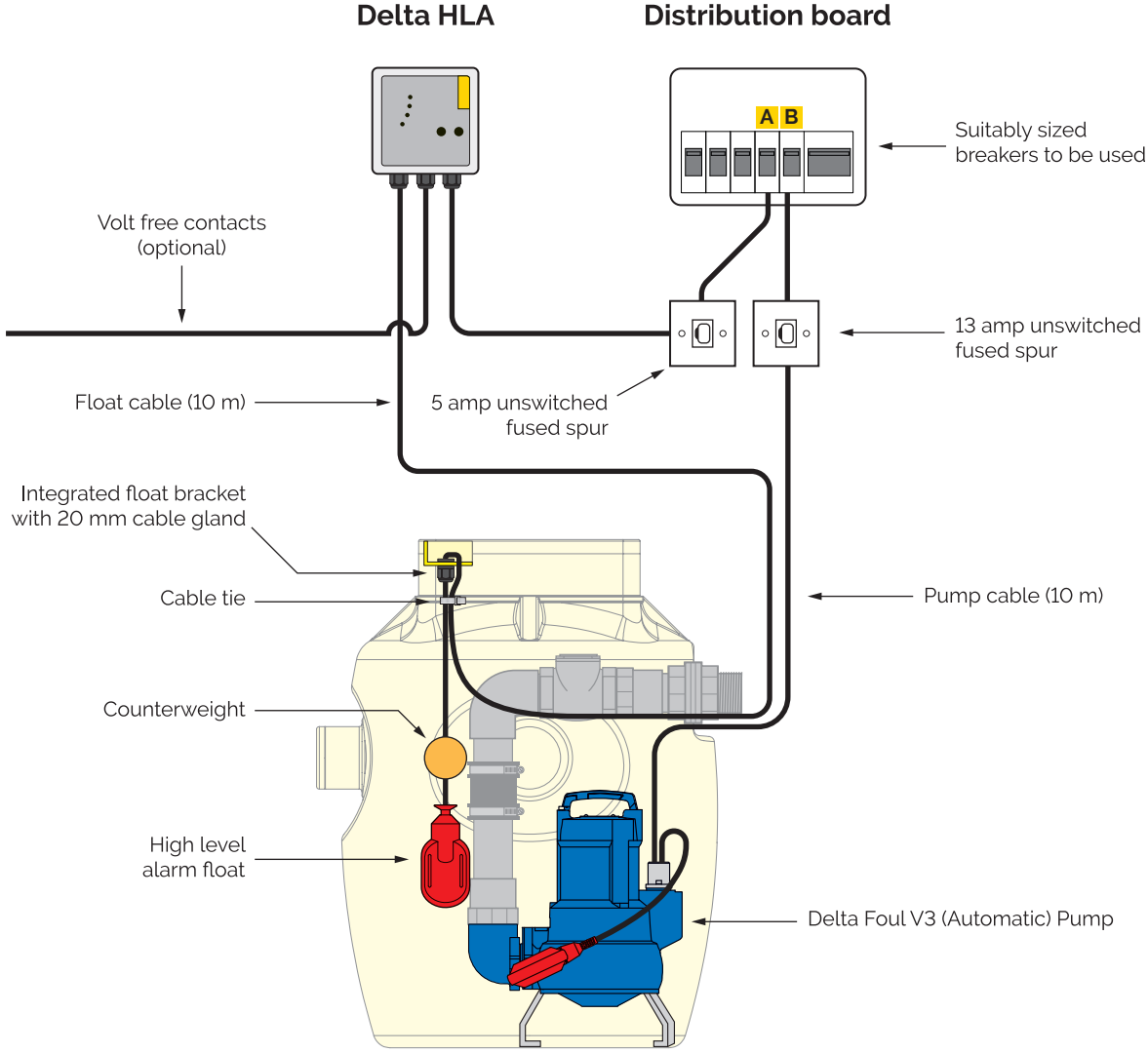

**BREAKER SPECIFICATION**

Description	Device type	Rating
A Delta HLA	MCB	6 A
B Delta Foul V3 Pump	RCBO, Type C	10 A

**6.2 Wiring diagram with Delta Battery Backup**

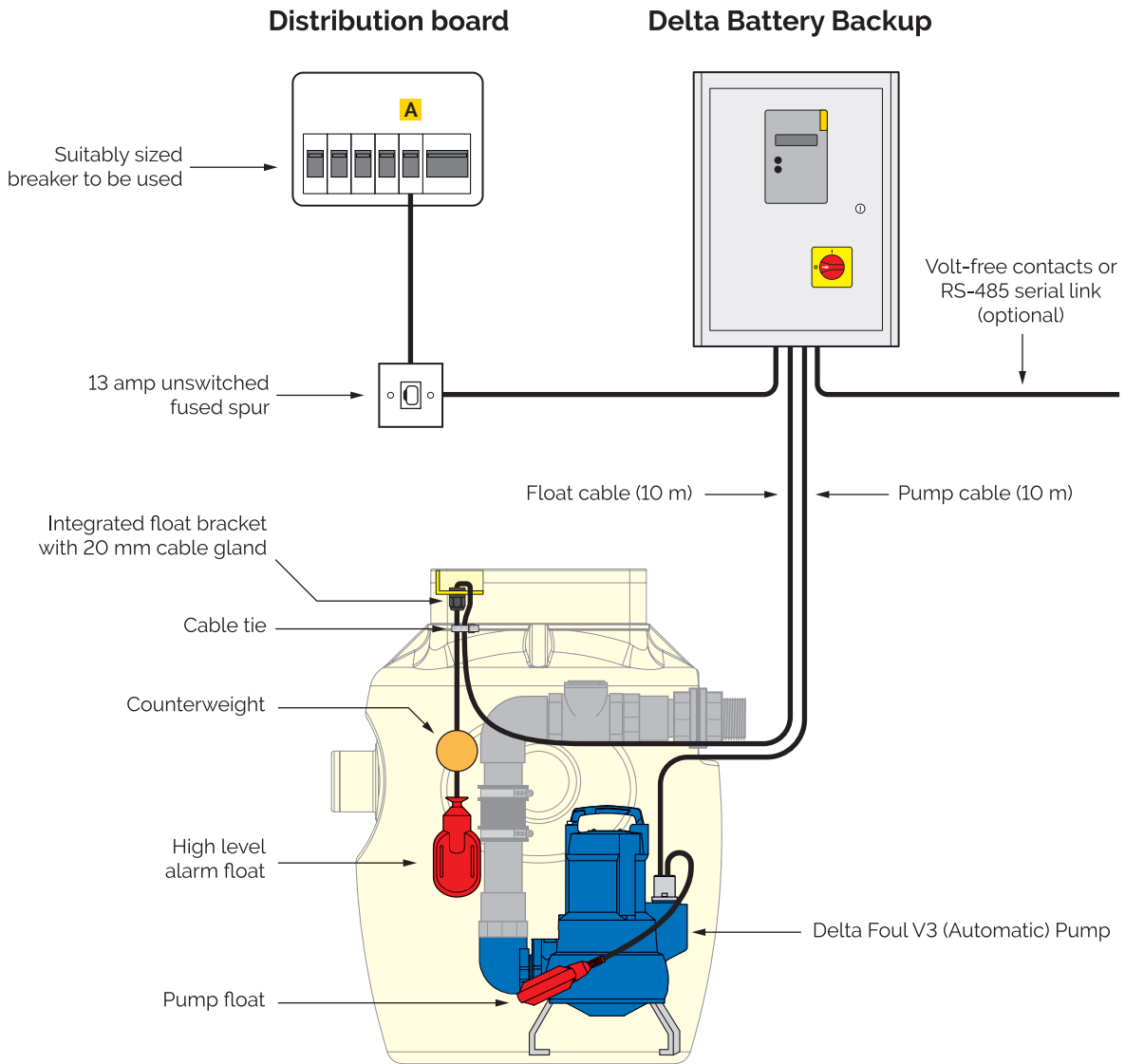

**BREAKER SPECIFICATION**

Description	Device type	Rating
A Delta Battery Backup Foul V3	RCBO, Type C	10 A

## 7. Maintenance

Sump pumps must be maintained. We recommend a qualified engineer examines and services equipment every year. Pumps running frequently due to higher water table, water drainage, or weather conditions should be examined more frequently, we recommend every 6 months. Sump pumps, being mechanical devices, may fail if not maintained which could lead to a flooded basement and costly repairs.

Regular servicing of sump pumps will increase efficiency and extend the life of the pump. All Delta pump systems should be maintained by one of our Delta Registered Pump Service Providers or installing contractor.

## 8. Health and safety

In order to minimise the risk of ill health or accidents when installing and/or servicing pump chambers, workers must be fully trained, competent and follow the health and safety guidelines below:

- Do not work without a risk assessment being in place.
- Work in accordance with the control measures identified in the risk assessment.
- All personnel must be vaccinated against diseases to which they may be exposed to, i.e. Tetanus, Polio, Hepatitis A&B, etc.
- At the time of writing, due to there being no vaccine against leptospirosis/Weil's disease, where rats may be present, ensure appropriate personal protective equipment (skin protection) is worn and ensure any cuts or abrasions are fully covered.
- There should be no eating or drinking during works and only afterwards following a change of clothing and washing.
- Ensure electrical power to the pump is turned off/isolated before carrying out installation or maintenance.
- A suitable first aid kit must be close to hand.

# 9. Warranty



## 9.1 Standard 12-month component warranty

The Delta Foul V3 packaged pumping station is offered with a 12-month component warranty from the date of invoice. This does not include submersible pumps, which have a standard 24-month warranty (refer to Section 9.2).

Standard Delta Membrane Systems Limited conditions apply.

This warranty does not cover defects caused by incorrect installation, installation/installer error, abnormal working conditions, misuse, or neglect.

Any defects or malfunctions should be reported to Delta Membrane Systems Limited within 7 days of when the defect becomes apparent. All broken components should be returned to Delta Membrane Systems Limited at customer cost.

To make a Warranty Claim, please email [pumps@deltamembranes.com](mailto:pumps@deltamembranes.com). Forms are available from [www.deltamembranes.com](http://www.deltamembranes.com).

In no event shall Delta Membrane Systems Limited be liable for any consequential damage, penalties, loss, or expenses howsoever arising, out of or in connection with incorrect installations or misuse, including, without limitation, direct or indirect loss, consequential loss or damage, loss of profit or goodwill, loss arising from any errors or omissions in the pump chamber as a result of, incorrect installation, installation/installer error, abnormal working conditions, misuse, or neglect.

Delta Membrane Systems Limited shall not accept liability if the pumping system fails due to being incorrectly specified by any third parties not employed by Delta Membrane Systems Limited.

Delta Membrane Systems Limited shall not accept liability if the pump system fails due to discharge of inappropriate fluids/solids including, but not limited to, building debris or materials.

### 9.1.1 Warranty from date of commissioning

When the Delta Foul V3 packaged pumping station is commissioned by a Delta Registered Pump Service Provider, the 12-month warranty period will begin at date of commissioning, subject to:

- all services and associated systems are ready to enable commissioning to take place;
- commissioning has been undertaken within 12 months from the date of invoice;
- the Delta Foul V3 packaged pumping station is commissioned by a Delta Registered Pump Service Provider;
- the Delta Registered Pump Service Provider has logged Commissioning details of the Delta Foul V3 packaged Pumping station with Delta Membrane Systems Limited;
- the Delta Foul V3 packaged pumping station is serviced by a Delta Registered Pump Service Provider with a minimum of a yearly service (within 12 months from the date of commissioning/last service) depending on site specifications.

## 9.2 Standard 24-month pump warranty

Delta Foul V3 Pumps are offered with a standard 24-month warranty from date of invoice. In other respects the terms of the pump warranty are the same as the standard component warranty.

When a Delta Foul V3 Pump is commissioned, and then serviced regularly by a Delta Registered Pump Service Provider an extended 5-year pump warranty is offered (subject to the terms and conditions).

### 9.2.1 Five-year extended pump warranty from date of commissioning



Delta Membrane Systems Limited will offer a 5-year extended pump warranty on the Delta Foul V3 Pump from date of commissioning, subject to:

- all services and associated systems are ready to enable commissioning to take place;
- the Delta Foul V3 Pump is commissioned within 12 months from the date of invoice;
- the Delta Foul V3 Pump is commissioned by a Delta Registered Pump Service Provider;
- the Delta Registered Pump Service Provider has logged Commissioning details of the Delta Foul V3 Pump with Delta Membrane Systems Limited;
- all Delta Foul V3 Pumps registered under the extended 5-year warranty must be serviced by a Delta Registered Pump Service Provider with a minimum of a yearly Service (within 12 months from the date of commissioning/last service) depending on site specifications.

# 10. Troubleshooting

Please ensure the installation process has been completed thoroughly and all steps have been followed correctly.

Use the table below to assist with troubleshooting and if problems still occur, please contact Delta Membranes on 01992 523 523 between 8am and 5pm, Monday to Friday or by email at [info@deltamembranes.com](mailto:info@deltamembranes.com)

Fault	Cause
Water is leaking from discharge arms.	<p>'O' rings missing or not installed correctly in unions.</p> <hr/> <p>PTFE tape not applied to male irons on discharge arms when attached to pumps.</p>
Pump isn't running.	<p>Pump hasn't got power – check wiring with reference to section 6.0 wiring diagram.</p> <hr/> <p>Float isn't lifting – check float arm is free moving and not catching on chamber or pipework – make sure pumps are positioned as diagram 30.</p>
The pump is running but is not pumping water or is discharging very slowly (taking more than 40 seconds to empty the chamber).	<p>Pump is air locked – make sure there is a level of water to the top of the pump. Remove pump from chamber and lower back into water, lift float to activate pump before reconnecting.</p> <hr/> <p>Discharge pipe is blocked – a drainage company is required.</p> <hr/> <p>Pump impeller is jammed – a drainage company is required.</p>
<div style="background-color: #c00000; color: white; padding: 5px; display: inline-block;">  <p><b>WARNING!</b>            Insure mains power and pump is isolated before taking pump apart and seek advice from a qualified electrician.</p> </div>	
Pump is tripping.	<p>Pump is wired incorrectly or not on a separate supply – refer to section 6.0 wiring diagram.</p> <hr/> <p>Pump impeller is jammed – a drainage company is required.</p>
<div style="background-color: #c00000; color: white; padding: 5px; display: inline-block;">  <p><b>WARNING!</b>            Insure mains power and pump is isolated before taking pump apart and seek advice from a qualified electrician.</p> </div>	
High level alarm is not functioning.	Refer to the high level alarm installation and operating instructions.



# 11. Ancillaries

**Pressure pipe, PVC Class E, 2 m**



1 1/4"    2"  
E100    E120

**Tank connector**



1 1/4"    2"  
E110    E130

**90° elbow PL/PL**



1 1/4"    2"  
E101    E121

**45° elbow PL/PL**



1 1/4"    2"  
E102    E122

**Tee-piece PL/PL**



1 1/4"    2"  
E105    E125

**Coupling (socket) PL/PL**



1 1/4"    2"  
E103    E123

**Socket union PL/PL**



1 1/4"    2"  
E106    E126

**Male threaded adaptor**



1 1/4"    2"  
E104    E124

**Coupling PL/TH**



1 1/4"    2"  
E107    E127

**Barrel nipple PL/TH**



1 1/4"    2"  
E108    E128

**Barrel nipple TH/TH**



1 1/4"    2"  
E109    E129

**Coupling TH/TH**



1 1/4"    2"  
E111    E131

**Male iron, Polypipe**



1¼" / 32 mm      2" / 50 mm  
E112                  E132

**Rubber drain coupling**



2"  
E174

**110mm saddle clamp, reinf.**



1¼"      2"  
E113      E133

**Gate valve, brass**



1¼"      2"  
E187      E188

**Swing check valve, brass**



1¼"      2"  
E191      E193

**110mm adaptor**



1¼"      2"  
E205      E206

**Solvent cement, WDF-05**



250 ml  
E175

**PVC cleaning fluid**



500 ml  
E176

**PTFE tape, roll**



12 mm x 12 m  
E177

# 12. Commissioning details

Property address	Commissioning engineers

Customer contact details	
Contact name	
Contact telephone	

Installation details	
Equipment installed	
Delta Registered Pump Service Provider	
Date of commissioning	
Commissioning engineer	
Signature of engineer	

**Servicing plans**

Sump pumps must be maintained. We recommend a qualified engineer examines and services equipment every year. Pumps running frequently due to higher water table, water drainage, or weather conditions should be examined more frequently, we recommend every 6 months. Sump pumps, being mechanical devices, may fail if not maintained which could lead to a flooded basement and costly repairs. Regular servicing of sump pumps will increase efficiency and extend the life of the pump. All Delta Membrane pump systems can be maintained and serviced by our recommended service companies or installing contractor.

**Commissioning**

All sump pumps require commissioning. Commissioning provides peace of mind, knowing that the system is installed correctly and in compliance with warranty conditions. All Delta Membrane pump systems can be commissioned by our recommended service companies or installing contractor.



Delta Membrane Systems Ltd, Delta House, Merlin Way, North Weald, Epping, Essex, CM16 6HR.

01992 523 523 [info@deltamembranes.com](mailto:info@deltamembranes.com) [www.deltamembranes.com](http://www.deltamembranes.com)

 [deltamembranes](https://www.facebook.com/deltamembranes)  [deltamembranes](https://twitter.com/deltamembranes)  [delta-membrane-systems-ltd](https://www.linkedin.com/company/delta-membrane-systems-ltd)  [deltamembranesystems](https://www.youtube.com/deltamembranesystems)